

**SV8247-9
 HIGH VACUUM (Positive Relief)
 SEAL-OFF VALVE
 1 Inch Size**

TABLE OF CONTENTS

INTRODUCTION2
 CONTACT INFORMATION2
 GENERAL NOTES AND WARNINGS2
INSTALLATION.....2
 GENERAL NOTES2
 WELDING VALVE IN PIPELINE3
OPERATION.....3
 EVACUATION.....3
 VACUUM CHECK3
MAINTENANCE.....3
 GENERAL NOTES3
INSTRUCTIONS4
Soft Goods Kit.....4
Plug and Disc Assembly Change-Out Kit.....4
Bellows Change-Out Kit.....4
Fredericks Thermocouple Change-Out Kit4
Disassembly.....4
Reassembly5

TABLE OF FIGURES

FIGURE 1 - SV8247-9.....6
 FIGURE 2 - EXPLODED CAP ASSEMBLY7
 FIGURE 3 - VO3-088T VALVE OPERATOR.....8

INTRODUCTION

This Installation, Operation, and Maintenance Manual is intended to be as complete and up to date as possible. It covers installation, operation, and maintenance procedures for a CPC-Cryolab product. CPC-Cryolab reserves the right to update this manual and other product information concerning installation, operation, and/or maintenance, at any time and without obligation to notify product owners of such changes.

CPC-Cryolab is not responsible for injury to personnel or product damage due to improper installation, operation, and/or maintenance. All installation, operation, and maintenance procedures should only be performed by trained/certified personnel. All personnel performing these procedures should completely and carefully read and understand all supplied materials before proceeding. All personnel should pay strict attention to all Notes, Cautions, and Warnings that appear within procedures detailed in this manual.

CPC-Cryolab welcomes user input as to suggestions for product or manual improvement.

CONTACT INFORMATION

For information concerning warranties, or for questions pertaining to the installation, operation or maintenance of CPC-Cryolab products, contact:

CPC-CRYOLAB
C/O LESLIE CONTROLS INC.
12501 Telecom Drive
Tampa, FL 33637
USA Phone: (813) 978-1000

To order replacement parts, contact CPC-Cryolab at address listed above, or call toll free:

USA/Canada/Caribbean Phone: (800) 323-8366
Please include model and serial number of unit for which parts are being ordered. If ordering by phone, please have this information readily available.

GENERAL NOTES AND WARNINGS

Notes:

- If the manual fails to answer all questions, or if specific installation, operation, and/or - maintenance procedures are not clearly understood, contact CPC-Cryolab for clarification before proceeding.
- If the unit is damaged during installation, operation, or maintenance, complete following steps:
 1. Turn-off and lock-out all supply to the unit in an approved manner, including incoming valves.
 2. Contact in-house maintenance personnel or CPC-Cryolab for further instructions.

Throughout this manual, warnings will be denoted as shown in the example below:

CAUTION!

Piping system must be adequately designed and supported to prevent extraordinary loads to pressure equipment.

CAUTION!

Serious injury or death can occur if not handled by properly trained personnel. Please consult the manufacturer with any questions prior to conducting work.

INSTALLATION

GENERAL NOTES

The valve and all associated parts should be unpacked and checked against the packing list and/or the approved customer drawing prior to installation. If parts are missing or there are more parts than necessary, contact CPC-Cryolab.

The valve is not to be installed or used in a pipeline that exceeds the maximum allowable working pressure listed on the valve tag.

Care must be taken during installation of oxygen cleaned and/or high purity valves to ensure the site is clean and the valves' cleanliness is not compromised.

WELDING VALVE IN PIPELINE

Prior to welding, ensure pipeline is clean and free from things such as dirt, weld slag, machining burrs, and pipe scale.

Disassemble the valve following the guidelines illustrated in the Maintenance section under Disassembly. Support the valve body securely until it is welded into the pipeline.

Weld valve into the pipeline in accordance with any and all applicable local and national codes and standards. Reassemble the valve following the guidelines illustrated in the Maintenance section under Reassembly.

OPERATION

Evacuation

CPC-Cryolab SV8247-9 vacuum positive relief seal-off valve is operated with the use of a valve operator. The valve operator matched with the SV8247-9 is the VO3-088T seen in Figure 3 on page 8.

Remove the relief cap from the seal off valve and take care to keep o-rings clean from contaminants. Thread the VO3-088T valve operator onto the valve body until hand tight. Connect the evacuation pump onto the valve operator. Open the valve by turning the valve operator knob counter clockwise and turn on the evacuation pump. Once the desired level of vacuum is achieved, close the seal-off valve by turning the valve operator knob clockwise, tighten by hand. Remove the valve operator from the valve body and replace the valve cap by hand tightening.

Vacuum Check

Remove the cap from the Fredericks thermocouple to expose the pins. Attach a vacuum gauge to the thermocouple taking care to keep the contacts clean and free of contaminants. Open the valve by turning the knob counter-clockwise two (2) turns. Once the reading is verified and recorded, turn the knob clockwise to close the valve and hand tighten. Remove the vacuum gauge from the thermocouple and replace the cap by hand tightening.

MAINTENANCE

WARNING!

Injury or death can occur due to failure to completely isolate equipment from all sources of pressure before beginning disassembly. Do not proceed until valve has been completely isolated from the process fluid and vented to atmospheric pressure.

GENERAL NOTES

Standard maintenance kits for the SV8247-9 include a soft goods kit to replace all elastomeric seals, a change-out kit to replace the plug and disc assembly, a bellows assembly change-out kit, and a thermocouple change-out kit. The plug and disc assembly change-out kit is provided pre-assembled, ready to drop into the valve body.

Lubricate all threads and o-rings sparingly with Krytox® 240-AC, Krytox® GPL206 or a USA engineering approved equivalent lubricant.

The Fredericks thermocouple must be installed using an epoxy vac seal on the threads. Approved sources for the epoxy vac seal are as follows:

1. Tra-Bond 2103 Manufactured by:
Tra-Con INC
45 Wiggins Ave.
Bedford, MA 01730
(800) 872-2661: Cage 22835
2. KL-320K Distributed by:
Kurt J Lesker Company
PO Box 10, 1925 Route 51
Clairton, PA 15025
(412) 387-9200: Cage KCRC9
3. Vacseal II Clear:
Aerosol: 0505 I-AB
Brush Applicator Bottle: 05049-AB
Supply Div. of Structure Probe INC
PO Box 656
West Chester, PA 19381
(610) 436-5400: Cage IP573
4. LOX 8 Paste
Flouramics INC
18 Industrial Ave.
Mahwah, NJ
(800) 922-0075: Cage 28017

The plug and disc assembly as well as the valve caps are to be tightened by hand only. The use of pliers or other tools can cause damage to the sealing surfaces which could void any warranty.

INSTRUCTIONS

Please refer to Figure 2 for a basic illustration of the cap assembly. Refer to Figure 1 for a basic illustration of the valve assembly. The numbers in parentheses below refer to the item number in the specified figures.

Soft Goods Kit

When installing a soft goods kit, only follow the instructions for the disassembly/reassembly of the cap, body, and bellows seal body. Disassembly of the Fredericks thermocouple and the plug and disc assembly is unnecessary except to replace the disc o-ring as outlined in the plug and disc assembly sections.

Plug and Disc Assembly Change-Out Kit

When installing a plug and disc assembly change-out kit, only follow the instructions for the disassembly/reassembly of the body. Disassembly of the cap, the plug and disc assembly, bellows seal valve body, and the Fredericks thermocouple is unnecessary.

Bellows Change-Out Kit

When installing a bellows change-out kit, only follow the instructions for the disassembly/reassembly of the bellows seal body. Disassembly of the cap, the plug and disc assembly, body assembly, and the Fredericks thermocouple is unnecessary. It is recommended to install a soft goods kit when installing a bellows change-out kit.

Fredericks Thermocouple Change-Out Kit

When installing a Fredericks thermocouple change-out kit, only follow the instructions for the disassembly/reassembly of the Fredericks thermocouple assembly. Disassembly of the cap, the plug and disc assembly, body assembly, and the bellows seal body is unnecessary.

Disassembly

Cap Assembly (Figure 2)

After ensuring the valve is isolated from all sources of pressure and completely depressurized, remove the cap assembly from the body. Take care not to contaminate any of the sealing surfaces while working on the valve parts. Remove the screw (23) from the top of the poppet (21) and release the chain (22).

Remove the retainer clip (17) from the poppet shaft while supporting the washer (18) and spring (19) as the spring is under compression and could leap off the shaft. Remove the washer and spring from the shaft and pull the poppet out of the cap body (16). Remove the o-ring (20), taking care not to scratch the sealing o-ring groove and sealing surface of the poppet.

Body Assembly (Figure 1)

After the cap (13) has been removed, attach the VO3-088T valve operator to the body (1) and tighten by hand. Turn the operator handle counter-clockwise until the plug and disc assembly is loose. Remove the valve operator from the body, then unscrew the plug and disc assembly removing it from the body. Remove the o-ring (7) from the top of the valve body being careful not to scratch the o-ring groove. Take care to keep the inside of the valve body clean and clear of debris while performing maintenance on the plug and disc assembly.

Plug and Disc Assembly (Figure 1)

After the plug and disc assembly has been removed from the body, place it vertically on a clean work surface. Using retaining ring pliers, remove the retaining ring (12) from the disc assembly while supporting the plug (11) as there is a spring under compression on the poppet shaft.

Remove the plug and spring (10) from the disc assembly. Remove the o-ring (8) from the disc (9) taking care not to scratch the o-ring groove.

Bellows Seal Body Assembly (Figure 1)

Remove the cap (6) from the bellows seal valve body (2) by turning it counter-clockwise. Using a wrench or socket, remove the retaining nut (5) from the bellows seal valve body. Remove the bellows assembly (4) taking care to keep the internal bellows seal valve body clean and clear of contaminants. Remove the o-ring (3) while being careful not to scratch any of the sealing surfaces.

Fredericks Thermocouple Assembly (Figure 1)

Using a wrench, remove the Fredericks thermocouple (14) from the bellows seal valve body (2). The thermocouple is installed with an epoxy seal on the threads and may take some force to initially loosen. Remove the cap and chain assembly (15) and the relief cap chain from the thermocouple. While the thermocouple is removed from the body, take care to keep the internal valve body clean and free of contaminants.

Reassembly

Plug and Disc Assembly (Figure 1)

Install a new o-ring (8) onto the disc. Refer to the GENERAL NOTES under the Maintenance section for important information regarding the proper lubrication of the o-rings prior to installation. Place the spring (10) onto the disc shaft (9). Push the plug (11) onto the shaft over the spring and using retainer ring pliers, install the retainer ring (12) on the disc shaft. Cycle the plug and disc a few times by hand to ensure the retainer ring has seated correctly.

Cap Assembly (Figure 2)

Install a new o-ring (20) onto the cap body (16). Refer to the GENERAL NOTES under the Maintenance section for important information regarding the proper lubrication of the o-rings prior to installation. Install the poppet (21) onto the cap body and place onto a clean, firm work surface.

Install the spring (19) onto the shaft. Push the washer (18) onto the shaft until the retainer ring groove is exposed. Push the retainer ring (17) into the groove until completely seated and release the washer.

Cycle the poppet a few times by hand to ensure the retainer ring has seated correctly. Slide the chain (22) end onto the screw (23). Apply Loctite to the threads of the screw and then thread the screw into the poppet. The chain should rotate freely on top of the poppet.

Body Assembly (Figure 1)

Install a new o-ring (7) into the o-ring groove on the valve body (1). Refer to the GENERAL NOTES under the Maintenance section for important information regarding the proper lubrication of the o-rings prior to installation.

Screw the plug and disc assembly into the body until resistance is felt. Refer to the GENERAL NOTES under the Maintenance section for important information regarding the proper lubrication of the threads prior to installation. Attach the VO3-088T valve operator to the valve body. Turn the operator knob clockwise by hand until the plug and disc assembly is tight in the body. Remove the valve operator from the body. Screw the cap assembly (13) by hand onto the top of the body until tight.

Bellows Seal Body Assembly (Figure 1)

Install a new o-ring (3) into the bellows seal valve body (2). Refer to the GENERAL NOTES under the Maintenance section for important information regarding the proper lubrication of the o-rings prior to installation. Insert the bellows assembly (4) into the bellows seal valve body. Screw the retaining nut (5) into the bellows seal valve body trapping the bellows assembly. Torque the retaining nut the 30-60

in-lbs. Install the cap (6) by hand on the bellows seal valve body until tight.

Fredericks Thermocouple Assembly (Figure 1)

Inspect the threads of the bellows seal valve body (2) and make sure they are clean and free of debris. Slide the chain end from the relief cap assembly (13) and the thermocouple cap assembly (15) onto the threads of the thermocouple (14). Apply an epoxy vac seal to the threads of the thermocouple. Refer to the GENERAL NOTES under the Maintenance section for important information regarding the proper epoxy vac seal to use prior to installation. Thread the thermocouple into the bellows seal valve body and tighten.

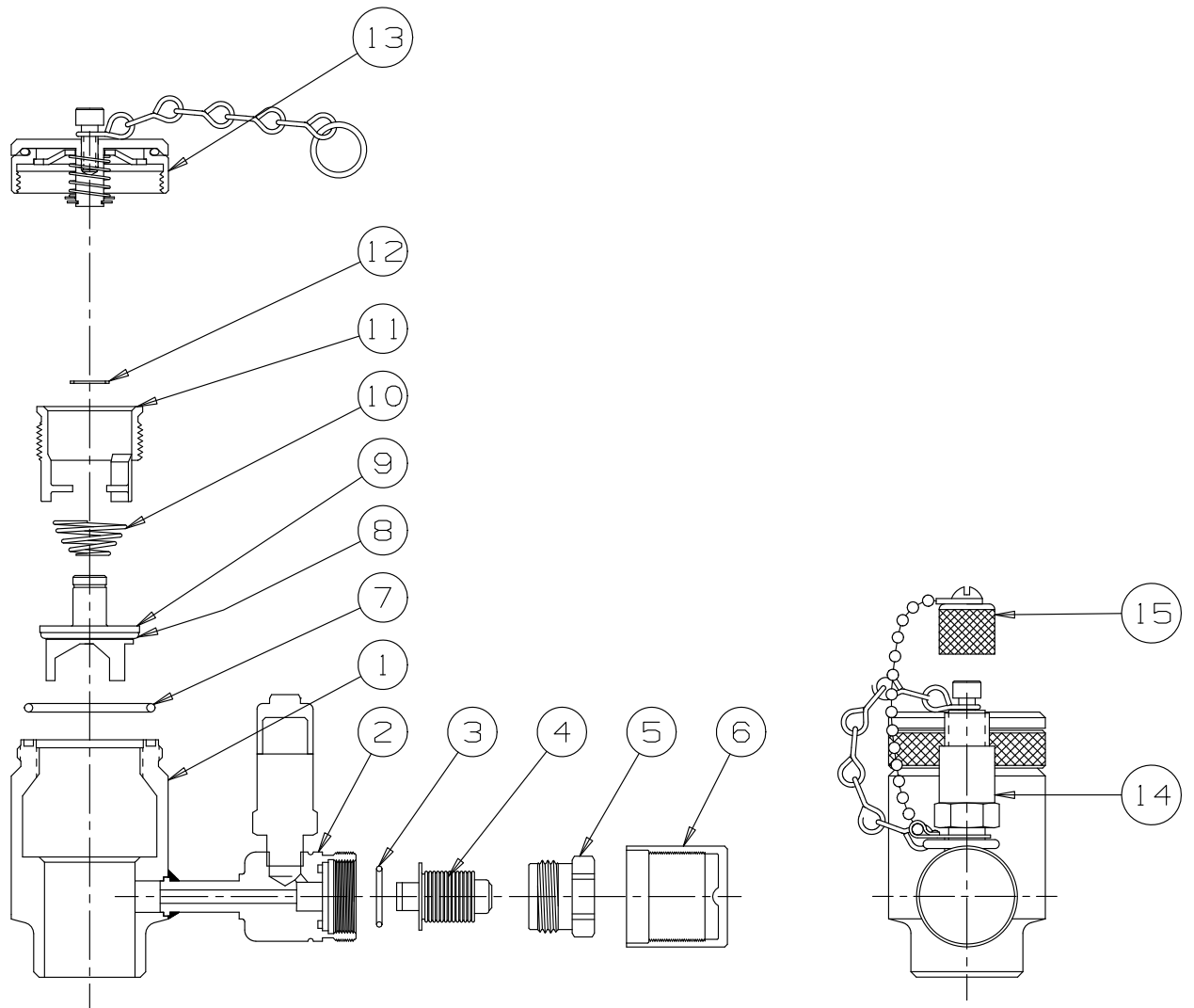

Figure 1 – SV8247-9

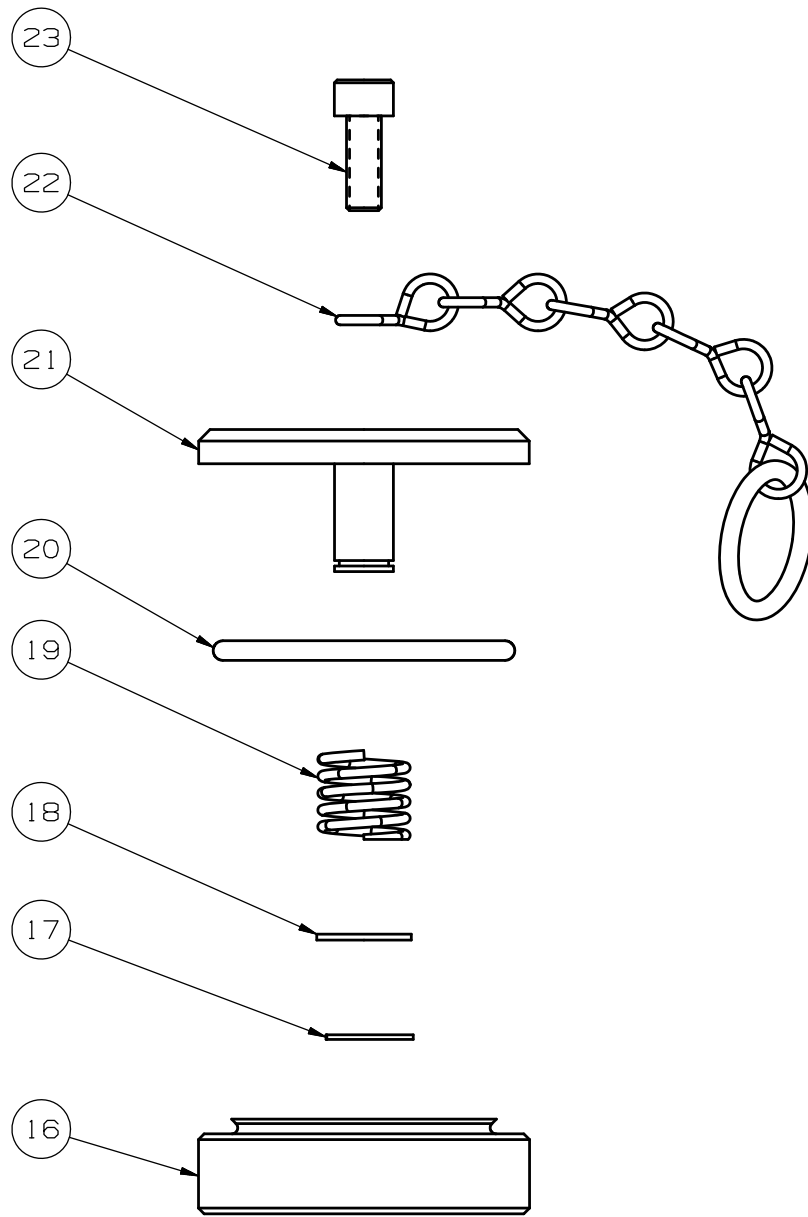

Figure 2 – Exploded Cap Assembly

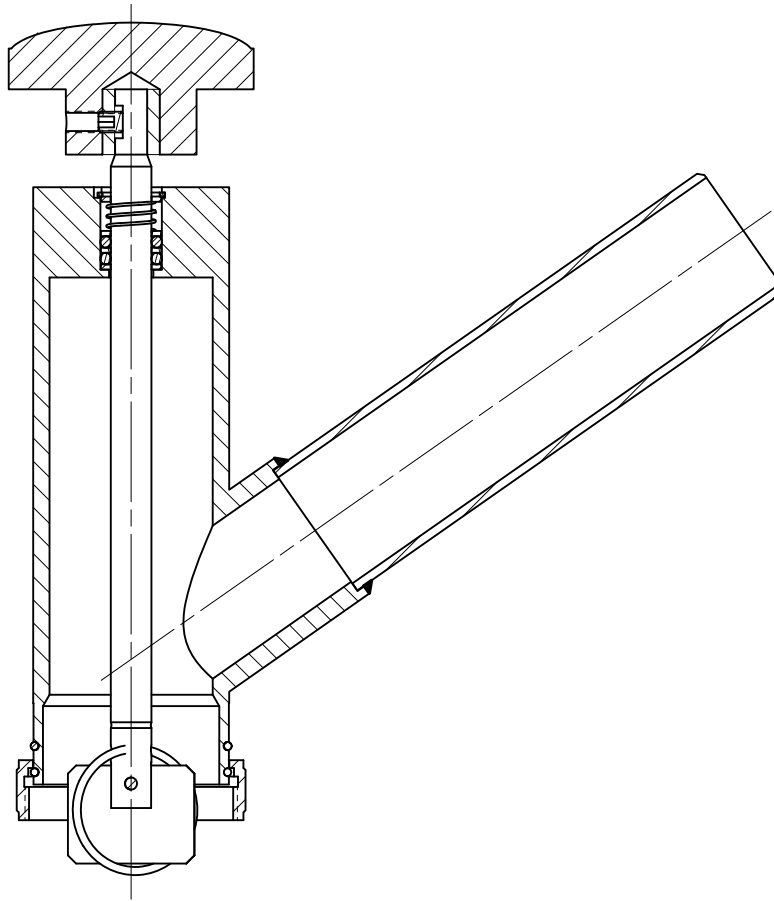

Figure 3 – VO3-088T Valve Operator

It is solely the responsibility of the system designer and the user to select products and materials suitable for their specific application requirements and to ensure proper installation, operation and maintenance of these products. Assistance shall be afforded with the selection of the materials based on the technical information supplied to CPC-Cryolab™; however, the system designer and user retain final responsibility. The designer should consider applicable Codes, material compatibility, product ratings and application details in the selection and application. Improper selection, application or use of the products described herein can cause personal injury or property damage. If the designer or user intends to use the product for an application or use other than originally specified, he must reconfirm that the selection is suitable for the new operating conditions.



12501 Telecom Drive, Tampa, FL 33637
Ph: (813) 978-1000 • Fax: (813) 977-3329
www.cpc-cryolab.com