

**SV2
 HIGH VACUUM (Positive Relief)
 SEAL-OFF VALVES
 1/2, 3/4, 1 Inch Sizes**

TABLE OF CONTENTS

INTRODUCTION	2
CONTACT INFORMATION	2
GENERAL NOTES AND WARNINGS	2
INSTALLATION	2
GENERAL NOTES	2
WELDING VALVE IN PIPELINE	3
OPERATION	3
SV2.....	3
MAINTENANCE	3
GENERAL NOTES	3
INSTRUCTIONS	3
<i>Soft Goods Kit</i>	3
<i>Plug and Disc Assembly Kit</i>	3
<i>Disassembly</i>	3
<i>Reassembly</i>	4

TABLE OF FIGURES

FIGURE 1 - STANDARD SV2.....	5
FIGURE 2 - SV2 AND VALVE OPERATOR MATCHING.....	6
FIGURE 3 - VO3 SERIES VALVE OPERATOR.....	6

INTRODUCTION

This Installation, Operation, and Maintenance Manual is intended to be as complete and up to date as possible. It covers installation, operation, and maintenance procedures for a CPC-Cryolab product. CPC-Cryolab reserves the right to update this manual and other product information concerning installation, operation, and/or maintenance, at any time and without obligation to notify product owners of such changes.

CPC-Cryolab is not responsible for injury to personnel or product damage due to improper installation, operation, and/or maintenance. All installation, operation, and maintenance procedures should only be performed by trained/certified personnel. All personnel performing these procedures should completely and carefully read and understand all supplied materials before proceeding. All personnel should pay strict attention to all Notes, Cautions, and Warnings that appear within procedures detailed in this manual.

CPC-Cryolab welcomes user input as to suggestions for product or manual improvement.

CONTACT INFORMATION

For information concerning warranties, or for questions pertaining to the installation, operation or maintenance of CPC-Cryolab products, contact:

CPC-CRYOLAB
C/O LESLIE CONTROLS INC.
12501 Telecom Drive
Tampa, FL 33637
USA Phone: (813) 978-1000

To order replacement parts, contact CPC-Cryolab at address listed above, or call toll free:

USA/Canada/Caribbean Phone: (800) 323-8366
Please include model and serial number of unit for which parts are being ordered. If ordering by phone, please have this information readily available.

GENERAL NOTES AND WARNINGS

Notes:

- If the manual fails to answer all questions, or if specific installation, operation, and/or - maintenance procedures are not clearly understood, contact CPC-Cryolab for clarification before proceeding.
- If the unit is damaged during installation, operation, or maintenance, complete following steps:
 1. Turn-off and lock-out all supply to the unit in an approved manner, including incoming valves.
 2. Contact in-house maintenance personnel or CPC-Cryolab for further instructions.

Throughout this manual, warnings will be denoted as shown in the example below:

CAUTION!

Piping system must be adequately designed and supported to prevent extraordinary loads to pressure equipment.

CAUTION!

Serious injury or death can occur if not handled by properly trained personnel. Please consult the manufacturer with any questions prior to conducting work.

INSTALLATION

GENERAL NOTES

The valve and all associated parts should be unpacked and checked against the packing list and/or the approved customer drawing prior to installation. If parts are missing or there are more parts than necessary, contact CPC-Cryolab.

The valve is not to be installed or used in a pipeline that exceeds the maximum allowable working pressure listed on the valve tag.

Care must be taken during installation of oxygen clean and high purity valves to ensure the site is clean and the valves' cleanliness is not compromised.

WELDING VALVE IN PIPELINE

Prior to welding, ensure pipeline is clean and free from things such as dirt, weld slag, machining burrs, and pipe scale.

Disassemble the valve following the guidelines illustrated in the Maintenance section under Disassembly-Body Assembly (page 3). Support the valve body securely until it is welded into the pipeline.

Weld valve into the pipeline in accordance with any and all applicable local and national codes and standards. Reassemble the valve following the guidelines illustrated in the Maintenance section under Reassembly.

OPERATION

SV2

CPC-Cryolab SV2 high vacuum positive relief seal-off valves are operated with the use of a valve operator. The valve operator is matched to the seal-off valve based on model and size (Figure 3 on page 7). A drawing of a valve operator can be seen in Figure 3.

Remove the relief cap and cap adapter from the seal off valve and take care to keep o-rings clean from contaminants. Thread the correct valve operator onto the valve body until hand tight. Connect the evacuation pump onto the valve operator. Open the valve by turning the valve operator knob counter clockwise and turn on the evacuation pump. Once the desired level of vacuum is achieved, close the seal-off valve by turning the valve operator knob clockwise, tighten by hand. Remove the valve operator from the valve body and replace the valve cap adapter and relief cap by hand tightening.

MAINTENANCE

WARNING!

Injury or death can occur due to failure to completely isolate equipment from all sources of pressure before beginning disassembly. Do not proceed until valve has been completely isolated from the process and vented to atmospheric pressure.

GENERAL NOTES

Standard maintenance kits for valves include a soft goods kit to replace all elastomeric seals and a plug and disc assembly kit to replace the plug and disc assembly. Plug and disc assembly kits are provided pre-assembled, ready to install in the valve.

Apply Krytox® or an equivalent lubricant that is compatible with the process fluid to all threads and o-rings prior to reassembly. It is important to only apply a thin coat of lubricant to the o-rings as excess lubricant can cause valve sticking.

The plug and disc assembly is to be tightened by hand only. The use of pliers or other tools can cause damage to the sealing surfaces which could void any warranty.

INSTRUCTIONS

Please refer to Figure 1 for a basic illustration of this type of valve. The numbers in parenthesis below refer to the item number in the specified figure. Ensure the valve is isolated from all sources of pressure and completely depressurized before proceeding.

Soft Goods Kit

When installing a soft goods kit, only follow the instructions for the disassembly/reassembly of the cap and the body. Disassembly of the plug and disc assembly is unnecessary except to replace the disc o-ring as outlined in the plug and disc assembly sections.

Plug and Disc Assembly Kit

When installing a change-out kit, only follow the instructions for the disassembly/reassembly of the body. Disassembly of the cap assembly as well as the plug and disc assembly is unnecessary.

Disassembly

Cap Assembly

The SV2 series valve utilizes a plastic cap and cap adapter for positive relief. Slide the plastic cap (9) off of the cap adapter (8). Unscrew the cap adapter from the body (1) to expose the plug and disc assembly.

Body Assembly

After the cap has been removed, attach the correct size VO3 valve operator to the body and tighten by hand. Use the table in Figure 2 to locate the proper valve operator. Turn the operator handle counter-clockwise until the plug and disc assembly is loose. Remove the valve operator from the body, then unscrew the plug and disc assembly removing it from the body. Remove the o-ring (7) from the top of the

valve body being careful not to scratch the o-ring groove. Take care to keep the inside of the valve body clean and clear of debris, while performing maintenance on the plug and disc assembly.

Plug and Disc Assembly

After the plug and disc assembly has been removed from the body, place it vertically on a clean work surface. Using retaining ring pliers, remove the retaining ring (5) from the disc assembly while supporting the plug as there is a spring under compression on the poppet shaft.

Remove the plug (2) and spring (4) from the disc assembly. Remove the o-ring (6) from the disc (3) taking care not to scratch the o-ring groove.

Reassembly

Plug and Disc Assembly

Install a new o-ring onto the disc. Refer to the GENERAL NOTES under the Maintenance section for important information regarding the proper lubrication of the o-rings prior to installation. Place the spring onto the disc shaft. Push the plug onto the shaft over the spring and using retainer ring pliers, install the retainer ring on the disc shaft. Cycle the plug and disc a few times by hand to ensure the retainer ring has seated correctly.

Body Assembly

Install a new o-ring into the o-ring groove on the valve body. Refer to the GENERAL NOTES under the Maintenance section for important information regarding the proper lubrication of the o-rings prior to installation.

Screw the plug and disc assembly into the body until resistance is felt. Refer to the GENERAL NOTES under the Maintenance section for important information regarding the proper lubrication of the threads prior to installation. Attach the correct size VO3 valve operator to the valve body. Turn the operator knob clockwise by hand until the plug and disc assembly is tight in the body. Remove the valve operator from the body. Screw the cap adapter by hand onto the top of the body until tight. Press the plastic cap onto the cap adapter by hand.

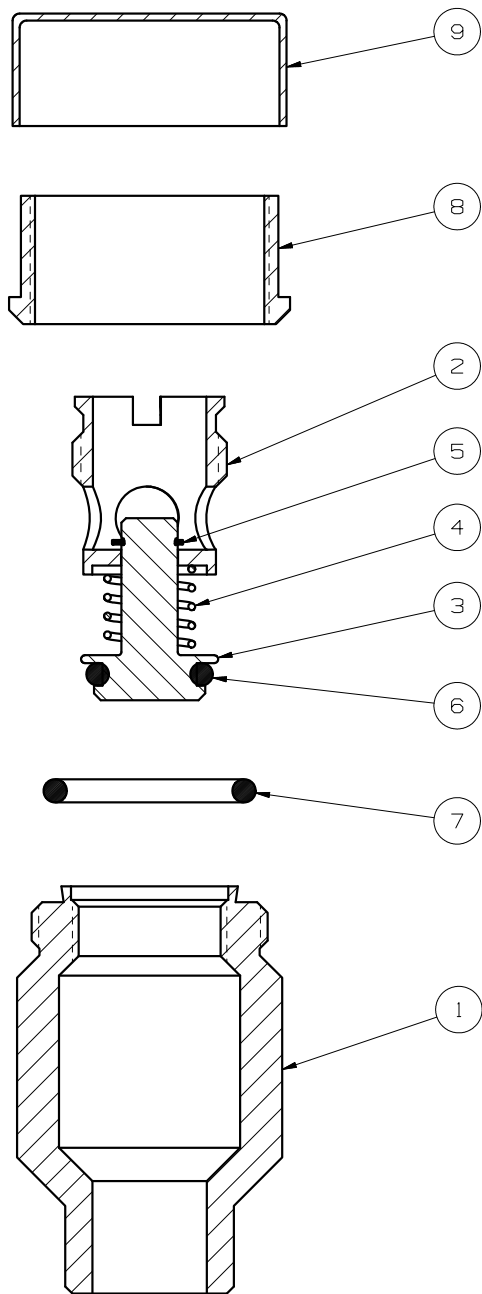

Figure 1 – Standard SV2

Standard Seal-off Valves and Valve Operators		
Size	SV2 Part Number	VO3 Part Number
1/2"	SV2-084-	VO3-084-
3/4"	SV2-086-	VO3-086-
1"	SV2-088-	VO3-088-

NOTE: Before operating or maintenance, be sure to have the correct valve operator for the seal-off valve being used.

Figure 2 – SV2 and Valve Operator Matching

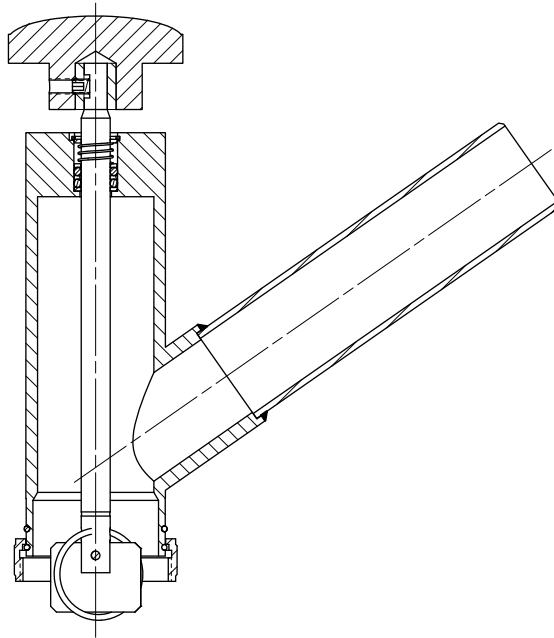

Figure 3 – VO3 Series Valve Operator

It is solely the responsibility of the system designer and the user to select products and materials suitable for their specific application requirements and to ensure proper installation, operation and maintenance of these products. Assistance shall be afforded with the selection of the materials based on the technical information supplied to CPC-Cryolab™; however, the system designer and user retain final responsibility. The designer should consider applicable Codes, material compatibility, product ratings and application details in the selection and application. Improper selection, application or use of the products described herein can cause personal injury or property damage. If the designer or user intends to use the product for an application or use other than originally specified, he must reconfirm that the selection is suitable for the new operating conditions.

