

# CPC Vacuum Jacketed Fill Hose

## TABLE OF CONTENTS

<b>INTRODUCTION .....</b>	<b>2</b>
<b>INSTALLATION.....</b>	<b>3</b>
GENERAL NOTES .....	3
PRIOR TO USE OF HOSE.....	3
START-UP.....	3
<b>OPERATION.....</b>	<b>3</b>
GENERAL .....	3
USE OF FILL HOSE .....	3
<b>MAINTENANCE.....</b>	<b>4</b>
GENERAL NOTES – IMPORTANT .....	4
LAYOUT.....	4
<b>REPLACEMENT PARTS .....</b>	<b>5</b>

## ILLUSTRATION INDEX

FIGURE 1 - GENERAL LAYOUT CONTINUED .....	6
---	---

# INTRODUCTION

This Installation, Operation, and Maintenance Manual is intended to be as complete and up to date as possible. It covers installation, operation, and - maintenance procedures for Leslie Controls, Inc. CPC Vacuum Jacketed Fill Hose. CPC-Cryolab reserves right to update this manual and other product information concerning installation, operation, and/or maintenance, at any time and without obligation to notify product owners of such changes.

CPC-Cryolab is not responsible for injury to personnel or product damage due to improper installation, operation, and/or maintenance. All installation, operation, and maintenance procedures should only be performed by trained/certified personnel. All personnel performing these procedures should completely and carefully read and understand all supplied materials before attempting procedures. All personnel should pay strict attention to all Notes, Cautions, and Warnings that appear within procedures detailed in this manual.

CPC-Cryolab welcomes user input as to suggestions for product or manual improvement.

## Contact Information

For information concerning warranties, or for questions pertaining to installation, Operation or maintenance of CPC-CRYOLAB products, contact:

CPC-CRYOLAB  
C/O LESLIE CONTROLS INC.  
12501 Telecom Drive  
Tampa, FL 33637

USA Phone: (813) 978-1000  
USA Fax: (813) 978-0984  
www.LESLIECONTROLS.com

To order replacement parts, contact CPC-Cryolab at address listed above, or call toll free:

USA/Canada/Caribbean Phone: (800) 323-8366  
Note: Please include model and serial number of unit for which parts are being ordered. If ordering by phone, please have this information readily available.

## GENERAL NOTES AND WARNINGS

### Notes:

- If questions are not answered by this manual, or if specific installation, operation, and/or - maintenance procedures are not clearly understood, contact CPC-Cryolab for clarification before proceeding.
- If unit is damaged during installation, operation, or maintenance, complete following steps:
  1. Turn off and lock out all supply to unit in an approved manner, including incoming valves.
  2. Contact in-house maintenance personnel or CPC-Cryolab for instructions.

NOTE: Throughout this manual, warnings will be denoted by BOXES

### **CAUTION!**

Piping system must be adequately designed and supported to prevent extraordinary loads to pressure equipment.

It is strongly recommended that this document be reviewed before attempting any installation, operation, or maintenance procedures.

# INSTALLATION

## GENERAL NOTES

Prior to installation, the hose assembly should be unpacked and checked against the packing list and/or the approved customer drawing.

Hose is not to be installed or used in an application that exceeds the maximum allowable working pressure as listed on the product tag.

Hose does have parts that are under vacuum. Care must be taken not to compromise this vacuum, as loss of this can affect the operation of hose. Please refer to the maintenance section for proper care in handling vacuum containing devices.

## PRIOR TO USE OF HOSE

Prior to use, insure use points and hose are free from dirt or debris. Inspect hose for any damage and consult manufacturer for any immediate questions or concerns.

If during or after use a system purge is necessary, the use of an inert gas is recommended so as not to introduce contaminants.

## START-UP

After initial cool down, check and re-tighten necessary connections. Refer to OPERATIONS section for proper torque values if pertinent.

# OPERATION

See Leslie application guide for other operating instructions.

## GENERAL

Hose is meant to be used as a connection between vessels to flow a cryogenic fluid. Hose is designed to optimize cryogenic flow by utilizing a vacuum between inner and outer piping. This annular space operates at an acceptable level of vacuum to help keep heat exchange to a minimum between ambient environment and cryogen.

## USE OF FILL HOSE

(Reference Figure 1)

This is the acceptable method for use of cryogenic fill hose. These steps should be closely followed to ensure safe operation of hose, to prevent damage to equipment, or even death to any one operating this equipment. Each individual gas supplier may have procedures in place for complete unloading of cryogenic media. This section is strictly for the hose, and does not cover the complete unloading format required by CGA and the industrial gas industry. For more information in the safe handling and delivery of cryogenic liquids, please refer to the Compressed Gas Association, Inc. manuals. For LIN, LOX, and LAR, CGA P-35-2001 and Hydrogen, CGA G-5-2005. If the flow media is not covered in either, please consult the hose manufacturer, or contact CGA directly.

- 1.) Visually inspect hose for any defects or damage that may make hose unsafe for use.
- 2.) Before connecting hose, remove dust covers from either end. Visually inspect the hose, as well as all connection points, for damage, debris, oil, grease, etc. that may cause an unsafe condition.
- 3.) Make sure male bayonet nose seal and coupling nut O-ring (Enlarged view in Figure 1) are not damaged and acceptable for use. If damaged, replace with new piece or consult with hose manufacturer.
- 4.) Insert male end into female receiving port on transport vessel. Tighten coupling nut with spanner wrench. Tighten to specified torque, no less than 75 ft-lb, but not to exceed 125 ft-lb. Blow out any excess debris prior to connecting other end of hose. Recheck torque after cool down.
- 5.) Once fill is completed, shut off all supply valves. Vent hose to atmospheric pressure before loosening connections. Hose may need purged and cleaned prior to storing. Refer to CGA standards for safe and acceptable methods of doing so.
- 6.) Once hose has warmed, visually inspect hose and replace end dust covers (29) hand tight prior to storage.

# MAINTENANCE

## WARNING!

Injury or death can occur due to failure to completely isolate equipment from all sources of pressure before beginning disassembly. Do not proceed until hose has been completely isolated from the process and vented to atmospheric pressure.

## GENERAL NOTES – IMPORTANT

Standard maintenance is required to maintain the integrity of hose. Replacement parts are available from the manufacturer when maintenance becomes necessary. A list of replacement parts is included in this section.

## LAYOUT

Please refer to “*Figure 1 – Layout with exploded Bayonet View*” for a basic illustration of hose. The numbers found in the balloons corresponds to the items located in the description box found in the upper corner of figure.

### Nose Seal and Coupling Nut O-Ring

The Nose seal is found on male bayonet section and the Buna O-ring on the face of coupling nut should be inspected for visual damage every time hose is used and replaced when necessary; however, it is recommended that the nose seal gets replaced after each fill. Replacement part numbers for these items can be found in replacement parts section.

### Dust Covers

The male bayonet connections found on hose have dust covers (29) that prevent excessive debris to build on inner line of hose when not in operation. These covers (29) should always be put in place once use of the hose is completed and the hose has had proper time to warm to ambient temperatures. This helps prevent introducing excessive pollutants into piping system. These covers should be tightened firm by hand; they do not require a torque value.

### Miscellaneous

For any items not discussed, please contact Manufacturer for proper handling.

# REPLACEMENT PARTS

These are the working parts on hose that would need replacement through the life of equipment. If there are any questions about these parts, please contact manufacturer.

<i>Replacement Parts List</i>			
<b><i>Evacuation Valve(27) and Relief Valve (28) Parts, per Figure 1</i></b>			
<u>Description</u>	<u>Part Number</u>	<u>Qty.</u>	
O-Ring (upper)	F-1308	1	
O-Ring (lower)	F-1309	1	
<i>If replacement of either valve becomes necessary, their part numbers are as follows:</i>			
Evacuation Valve (27)	F-1173	1	
Evacuation Valve Soft Good Kit	F-1173-SGK	1	
Relief Valve (28)	F-1174	1	
Relief Valve Soft Good Kit	F-1174-SGK	1	
<b><i>Hose Operational Parts</i></b>			
Dust Cover	F-1255	One Req'd for each end	
Nose Seals	F-971	One Req'd for each end	
(coupling nut) O-Ring (face)	F-1334	One Req'd for each end	

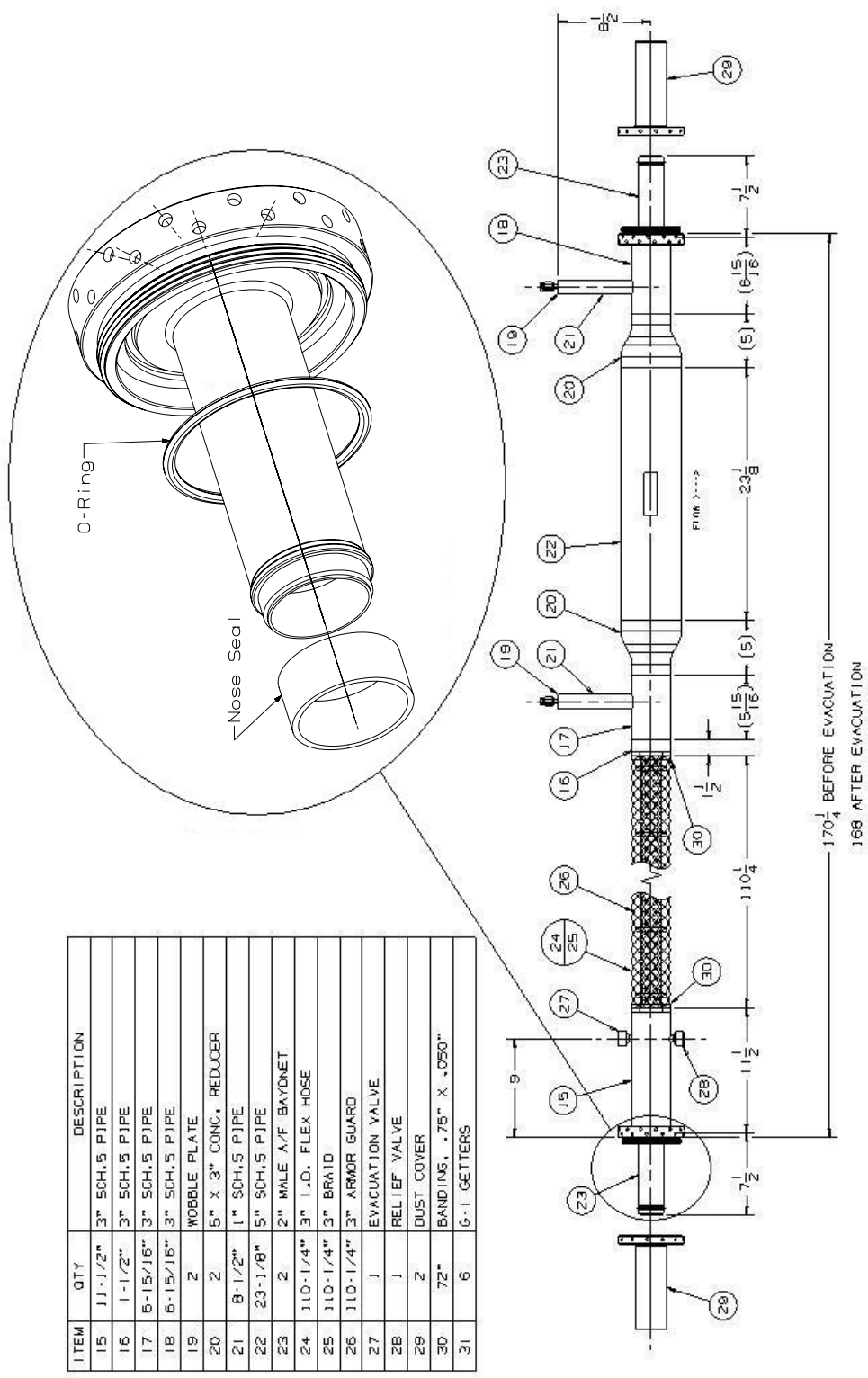

ITEM	QTY	DESCRIPTION
15	1	1-1/2" 3" SCH.5 PIPE
16	1	1-1/2" 3" SCH.5 PIPE
17	6	15/16" 3" SCH.5 PIPE
18	6	15/16" 3" SCH.5 PIPE
19	2	NOBLE PLATE
20	2	5" X 3" CONC. REDUCER
21	8	1/2" 1" SCH.5 PIPE
22	23	1/8" 5" SCH.5 PIPE
23	2	2" MALE A/F BAYONET
24	110	1/4" 3" I.D. FLEX HOSE
25	110	1/4" 3" BRAID
26	110	1/4" 3" ARMOR GUARD
27	1	EVACUATION VALVE
28	1	RELIEF VALVE
29	2	DUST COVER
30	72	BANDING, .75" X .050"
31	6	G-I GETTERS

Figure 1 - Layout with Exploded Bayonet View



*It is solely responsibility of system designer and user to select products and materials suitable for their specific application requirements and to ensure proper installation, operation and maintenance of these products. Assistance shall be afforded with selection of materials based on technical information supplied to Leslie Controls Inc.; however, system designer and user retain final responsibility. Designer should consider applicable Codes, material compatibility, product ratings and application details in selection and application. Improper selection, application or use of products described herein can cause personal injury or property damage. If designer or user intends to use product for an application or use other than originally specified, he must reconfirm tat selection is suitable for new operating conditions. Life expectancy for this product defaults to warranty period of sales contract.*